

## 1. INTRODUCTION

Robust and versatile locomotion as animals and humans are capable of is not yet achieved in technical systems. Stable adaptable gaits at different speeds and on changing surfaces today are implemented only in few robots and require immense control effort. On the other hand nature shows, that stable gait may be controlled by simple pattern generators. Adaptable mechanics may handle a range of disturbances before active control is needed. This poster presents a biomimetic approach to use biological data as inspiration to design a fast and robust biped robot.

## 2. FUNCTIONAL BIOMIMETICS

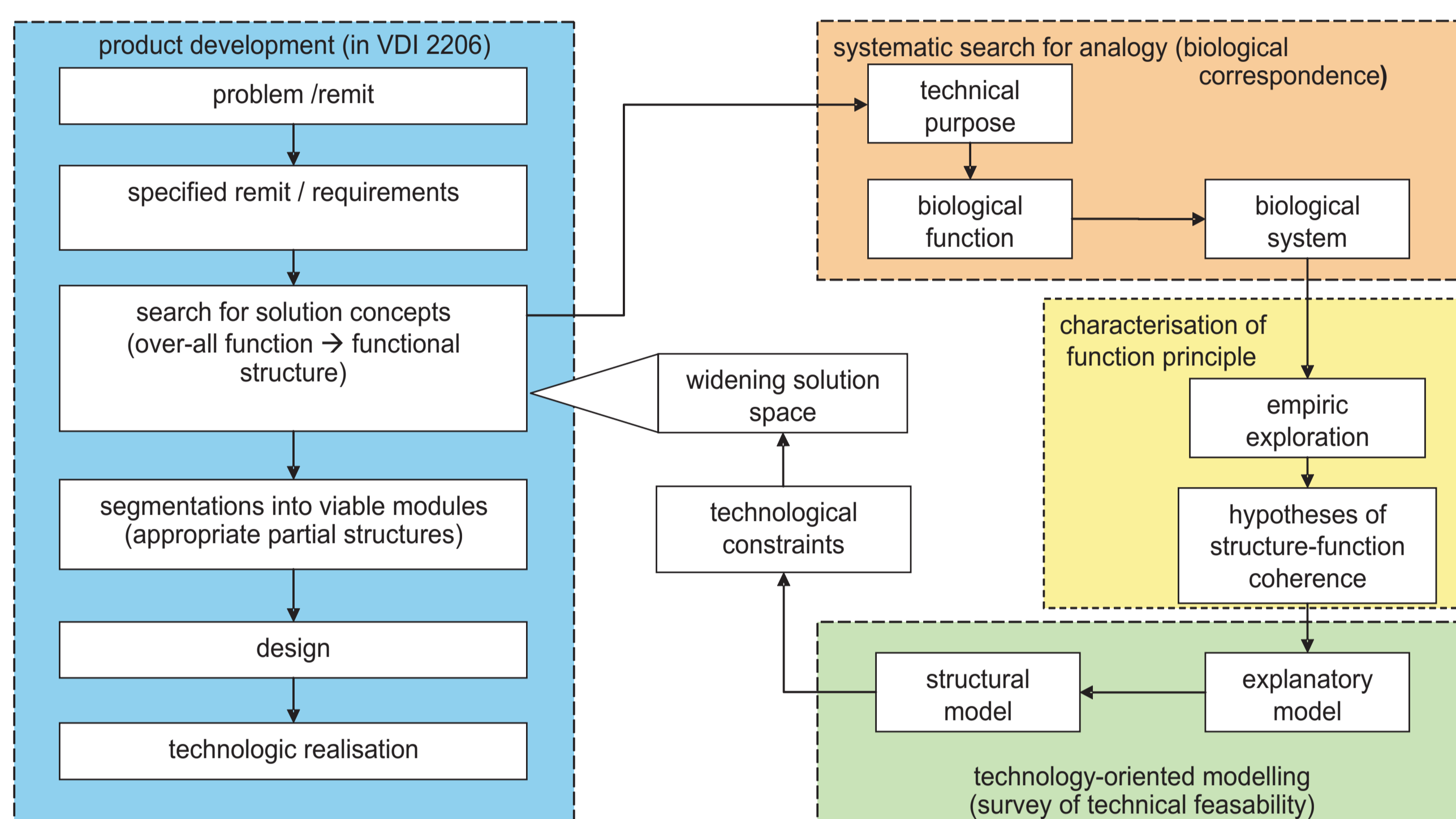

Figure 1: functional biomimetics in technical development (S<sup>+</sup>05)

**DEFINITION Functional Biomimetics:** Functional biomimetics as a scientific discipline deals with systematical technical implementation of biological structures, methods and development processes of biological systems (N<sup>+</sup>93).

## 3. BIOLOGICAL DATA

A variety of properties of human and animal gait are investigated based on kinetic and kinematic data acquired in experiments on an instrumented treadmill including high speed motion capturing:

- GRF, COM-motion, COP-motion
- angular joint motion, joint stiffness, joint torques
- muscularly produced work

It became obvious, that elastic behaviour and adaptable compliance of joints during a gait cycle are of vital importance for stable and robust locomotion.

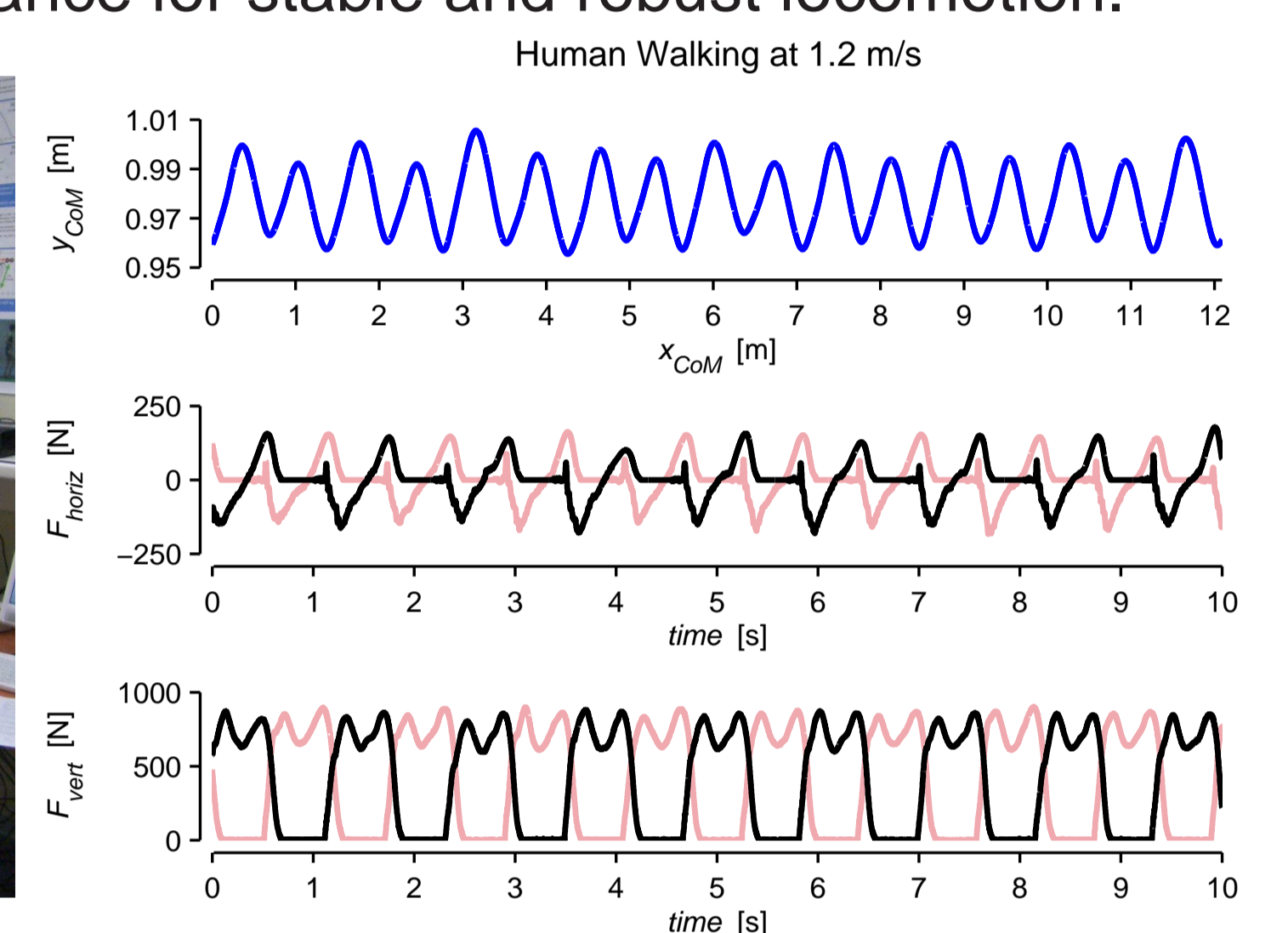
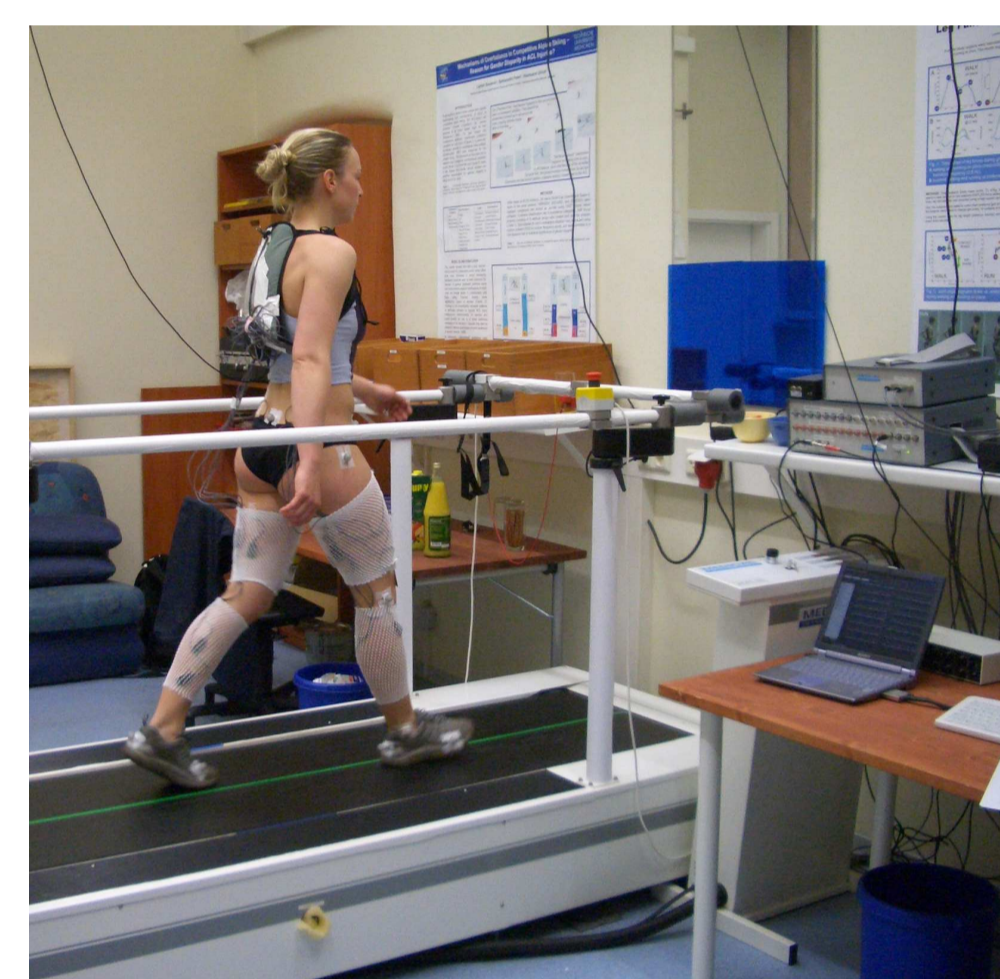

Figure 2: gait experiment on instrumented treadmill, COM-motion and GRF

## 4. MODEL-BASED DESIGN

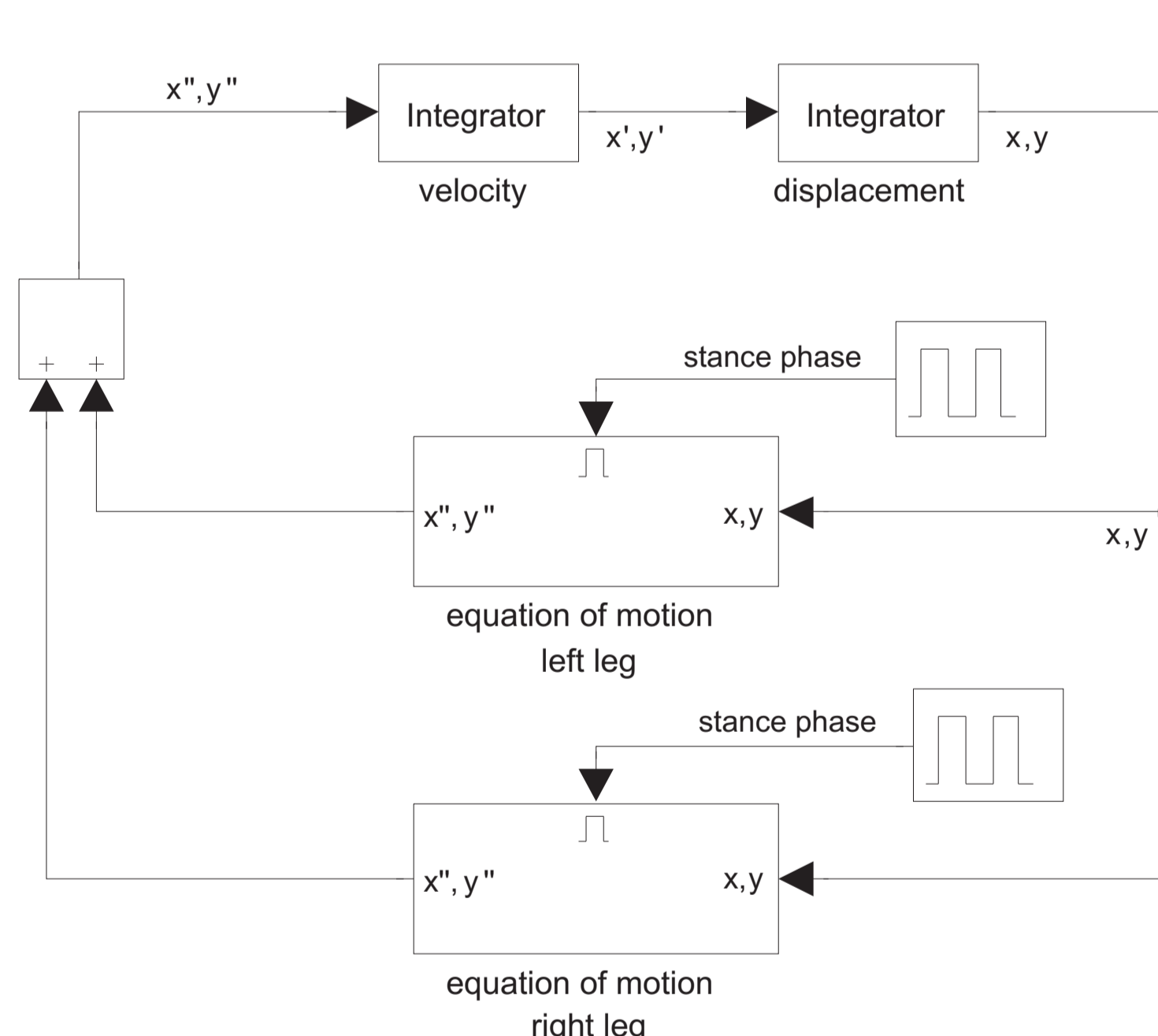

Figure 3: computer model of biped spring-mass walker in MATLAB SIMULINK simulating motion, ground-reaction-force and energy

As mobile robots require high efficiency in energy consumption and possess limited computing power it is a high motivation to replace controlling effort through elastic mechanisms and adaptable compliance. Based on computer models for biped walking (G<sup>+</sup>06) different properties as motional dimensions, forces and energy are analyzed. Advanced computer models allow rapid design and testing of mechanical structures and control algorithms. Experimental data constitute a resilient groundwork to inspire mechanical elements that reproduce mechanical properties of motion of legged creatures.

l	$\alpha$	m	x <sub>0</sub>	y <sub>0</sub>	v <sub>x0</sub>	v <sub>y0</sub>	E <sub>0</sub>
1m	69°	80kg	0	0.97m	1.2 m/s	0 m/s	827 J

Table 1: example parameters of the computer model

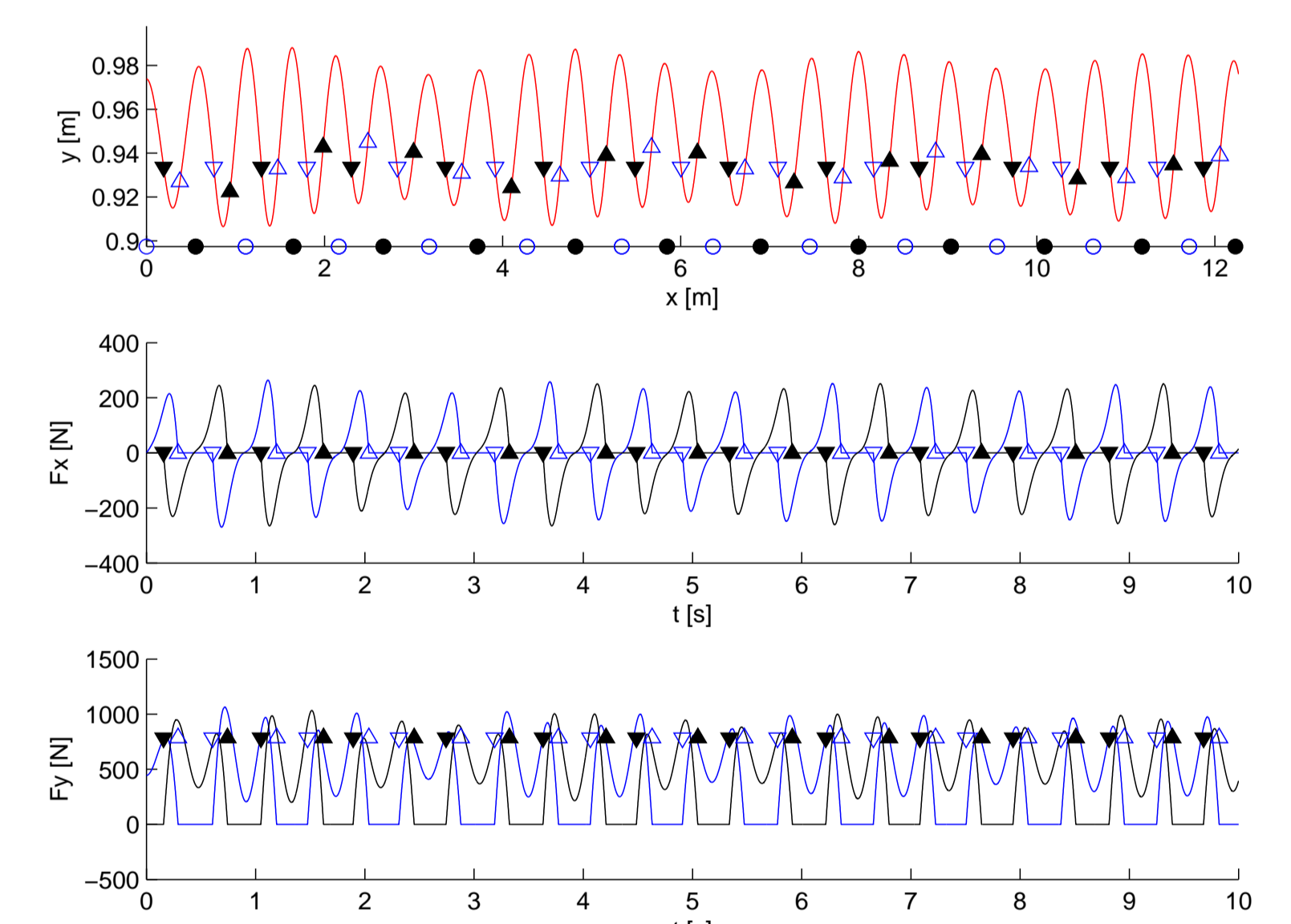

Figure 4: motion (red graph) and ground-reaction force (blue and black graphs) from MATLAB SIMULINK model with touch-down (triangle down), take-off (triangle up) and footpoint (circle) of left (blue) and right (black) feet

## 5. MECHANICAL DESIGN

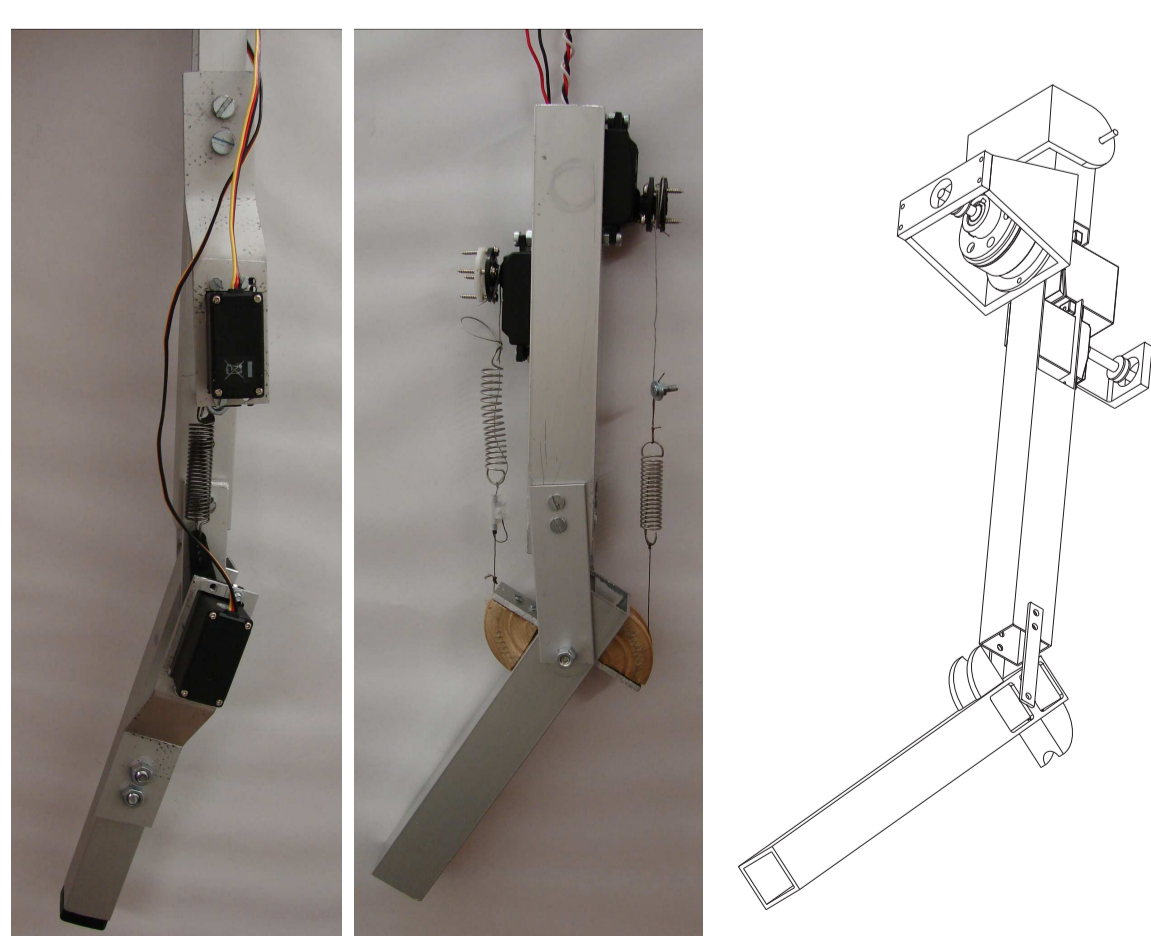

Figure 5: adaptive compliant mechanisms: Macepa (H<sup>+</sup>06) knee joint (left), antagonistic knee joint (center), concept of antagonistic knee joint with detachable spring (right)

## 6. NEURONAL CONTROL

In biological experiments it was shown that simple gait is driven by neuronal pattern generators. Simple gait and minor disturbances do not require a higher level control intervention (Cru02). The aim is to implement a learning neuronal network that is capable of exploring the hardware's mechanical properties, produce different gait patterns and adapt to disturbances.

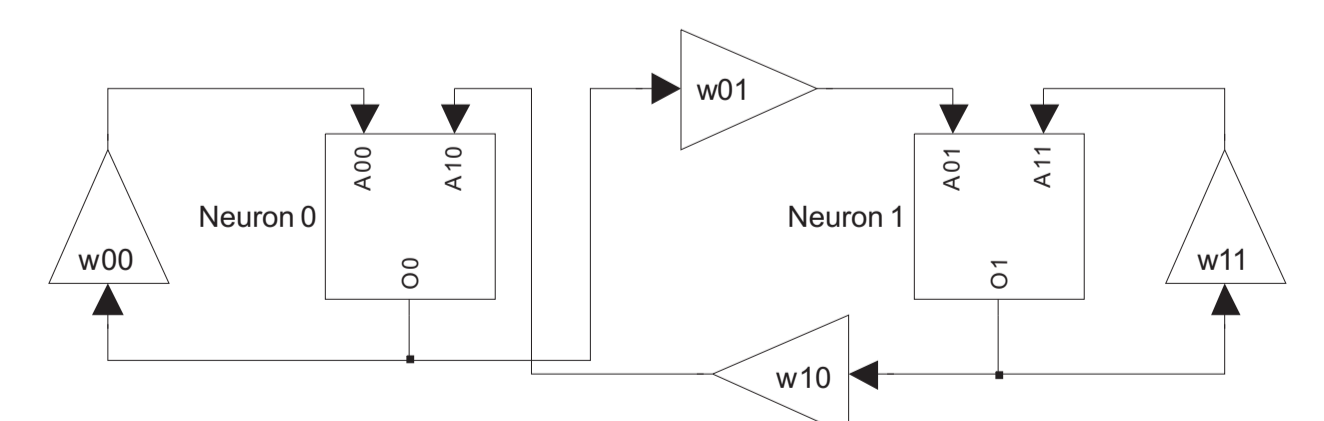

Figure 6: simple neuronal oscillator in MATLAB SIMULINK

## References

Cru02 CRUSE, Holk: The functional sense of central oscillations in walking. In: *Biological Cybernetics* 86 (2002), Nr. 4, S. 271-280  
 G<sup>+</sup>06 GEYER, H. u. a.: Compliant leg behaviour explains basic dynamics of walking and running. In: *Proc. R. Soc. London B* 273 (2006), Nr. 1603, S. 2861-2867  
 H<sup>+</sup>06 HAM, Ronald V. u. a.: MACCEPA: the Actuator with Adaptable Compliance for Dynamic Walking Biped. In: *CLAWAR* (2006), S. 759-766

N<sup>+</sup>93 NEUMANN, D. u. a.: Technologieanalyse Bionik. In: *Exemplarische bionische Projekte: Verminderung des Strömungswiderstands durch bionische Oberflächen*. 1 (1993), S. 123  
 S<sup>+</sup>05 SCHILLING, Cornelius u. a.: Towards a Bionic Algorithm. In: *AMAM* (2005), S. 3